

Output power:	max. 24000 Watt	Typical applications:	Laboratory plating lines
DC current:	max. 2000A (at 12V)	Precious metal plating	Reel-to-reel plating
DC voltage:	max. 1000V (at 24A)	PCB lines	Manual plating lines

DC power supply with switch mode technology, designed for use in electroplating and/or for installation in a cabinet.

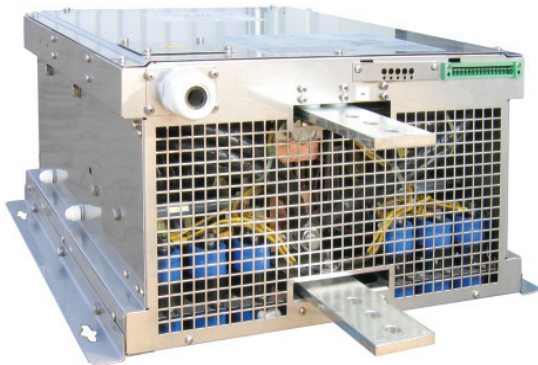

POWER STATION pe3000-6, front view



POWER STATION pe3000-6, back view

Characteristic values

Linearity inaccuracy:

- for amperage < 1 %
- for voltage < 0.5 %

Ripple less than < 1 %

Efficiency typical > 85 %

Powerfactor $\cos \phi$ 0,95

Constant current and voltage control

Soft start function

Over temperature protection

Pulse operation optional

Mains supply: standard 3x400 V +/- 10 % / 50-60 Hz without N (other voltages on request)

Cooling

Optimized cooling air guiding, air consumption
up to 15000W max. 540m³/h
up to 24000W max. 800m³/h

Cooling air outlet at the air grids (turned air flow on request)

Ambient temperature 35°C (other on request)

Design

Stainless steel casing, optional coated, protection grade IP20

DC connection via screw terminals or tin plated copper bus bars

High voltage proof DC terminals (above 60 V)

EMV: EN55011 class A, group 1 ; EN61000-6-4 and EN61000-6-2;
CE-conformity IEN50178 - low voltage guide line

Values	Standard sizes – DC output ¹										other sizes on request	
	2000 A			1200 A	1000 A	800 A	600 A		500 A	24 A		
DC current	2000 A			1200 A	1000 A	800 A	600 A		500 A	24 A		
DC voltage	6 V	10 V	12 V	20 V	15 V	20 V	20 V	24 V	30 V	1000 V		
Mains supply	3 x 400 V AC											
Weight	approx. 45 kg											

Standard dimensions

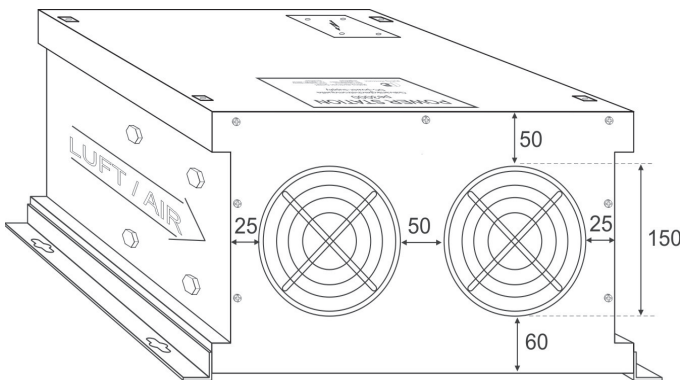
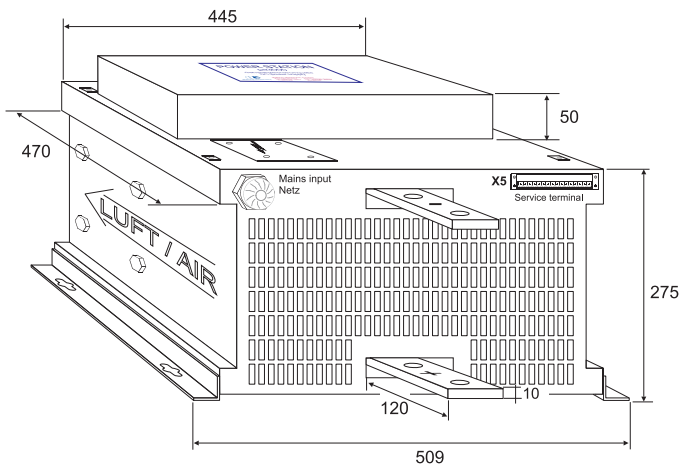

Control

Standard: peRB-interface

Optional: external control via analog signals, also with integrated isolation amplifier

Signals: 0-10V
0-1V
4-20mA
0-20mA (other on request)

Control unit pe280 for the controlling of DC power supplies

Designed for electroplating applications
Large 3-line LCD-display, Keypads for
easy programming/selection

Current and voltage infinitely adjustable
by UP / DOWN buttons

Current and voltage preset

Ampere-hour counter (totalizer)

Protection grade: IP54

Ambient temperature max. 40°C



Optional available functions

Preset counter, dosage counter *

Ramp function (start / stop ramp)

Timer function for ON / OFF *

Voltage / current alarm *

Operating hours counter

Chopper timer (pulse-capable rectifier type requested)

Pole changer function (mechanical / electronic) *

Programmable DC steps (14 individual steps) *

Extern ON

* Indication / alarm output

Control via: RS485, PROFIBUS, TCP/IP (other on request)

DC output bus bars

Tin-coated copper bars

Size, location and design of the DC output bus bars may differ
from the standard

Technical equipment, design and features: subject to change! For further information please contact plating electronic GmbH.